

Motorsport UK Championship Permit Number(s)

Championship Grade A

- British Rotax Micro Max CH2024/K005
- British Rotax Mini CH2024/K006
- British Rotax Junior Max CH2024/K007
- British Rotax Senior Max CH2024/K008

CHAMPIONSHIP BULLETIN: 01

The following Clarification is made to the published Championship Regulations for the above Championship and forms part of the Official Documents for the purposes of NCR D.8.1.

Addendum/changes (highlighted in yellow) to Motorsport UK ROTAX Technical Regulations 2024 v2 (or as subsequently updated) for British Kart Championships Events only and with immediate effect:

4.6.1 Reed Valve Assembly

The reed valve assy. is equipped with 2 petal stops and 2 reeds, each having 3 petals.

	Measurement	Tolerance
Thickness of reeds	0.60mm	+0.10mm -0.10mm



Flattening of the curved reed valve stopper plates is forbidden.

The minimum gap between the 2 curved stopper plates must be greater than **16.70mm**.

The measurement must be taken using a digital calliper from the inside surface of the stopper plates in line with the middle of each reed petal, as indicated by the red lines in the picture.

5.8 Carburettor

...

Needle valve assembly stamped "150".

A pin gauge measuring 1.56mm must not pass through the bore of the Needle valve.

Needle of needle valve marked with diamond symbol "INC" only.

...

5.10 Fuel Filter

...

Except the fuel line, the fuel pump and the original fuel filter no additional parts are permitted to be mounted between fuel tank and carburettor.

It is advised and permitted to use fuel hose clamps on all fuel and pulse lines to provide a secure seal.

5.14.1 125 Micro MAX (Micro Cadet) & 125 Mini MAX (Inter) Exhaust

...

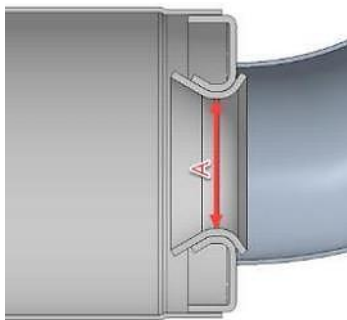

A solid flat plate measuring 28.0mm and 1.5mm thick must not pass through section A and a steel ball with a 26.0mm diameter must be able pass through section A in the below diagram from the inlet and through the 90-degree elbow completely. All exhaust gases must pass through Section A. (Internal exhaust components must first be removed)

...

5.14.3 125 Mini MAX (Inter) Perforated Tube & Isolation Mat

Perforated tube ROTAX part number: 273211.

The measurements in the diagram to the right are as follows:

- (a) minimum 481mm
- (b) minimum outside diameter of 61 mm
- (c) maximum outside diameter of 26 mm
- (d) minimum length 63 mm

...

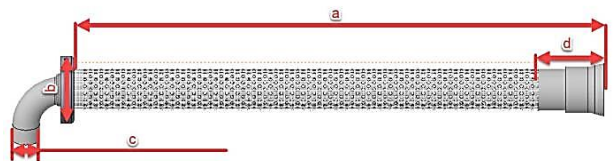

Signed: 

Danielle Short – Championship Coordinator 23rd July 2024